

Dimensions of MSD-M / MSD-LM

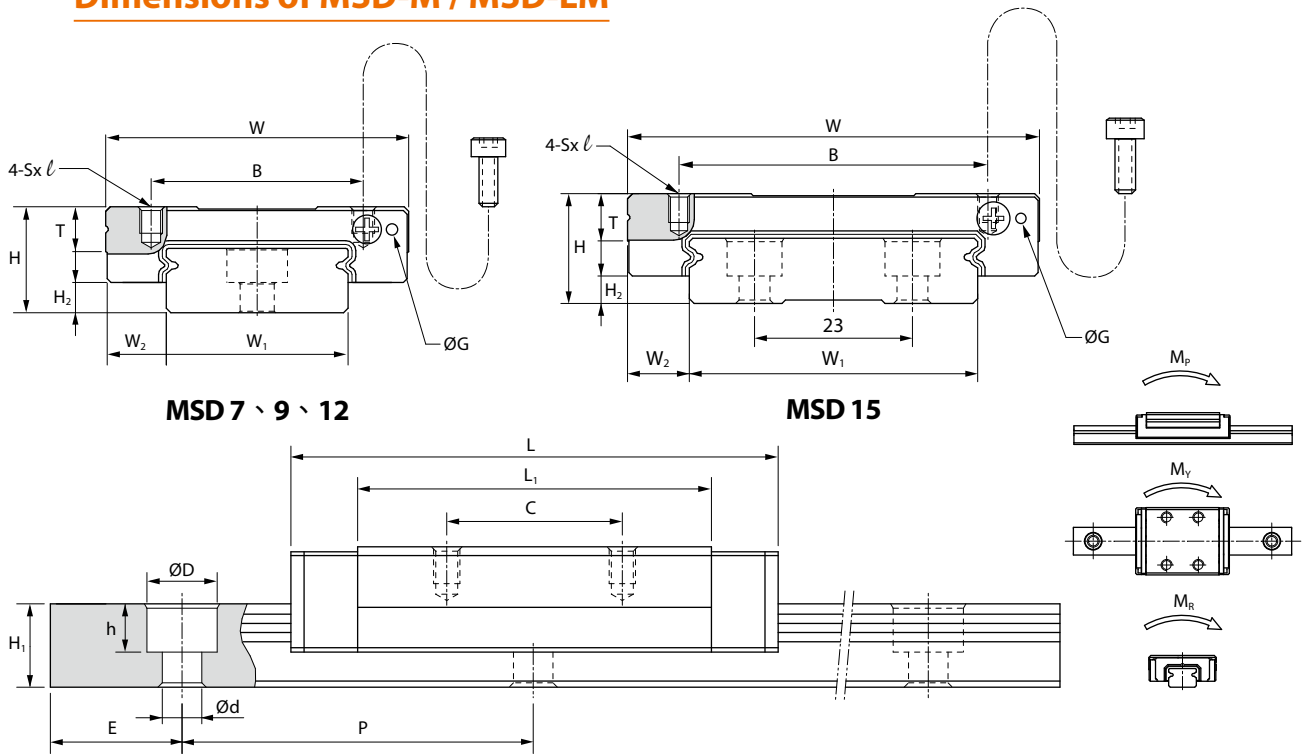

Unit: mm

| Model No. | External dimension | | | | | Carriage dimension | | | | | |
|-------------------------------------|--------------------|---------|--------------|-------|-------|--------------------|----------|-----------------|--------------|-----|-------------------|
| | Height H | Width W | Length L | W_2 | H_2 | B | C | $S \times \ell$ | L_1 | T | G |
| MSD 7 M MSD 7 LM | 9 | 25 | 30.8 40.5 | 5.5 | 2 | 19 | 10 19 | M3×3 | 20.6 30.3 | 3.9 | $\varnothing 1.5$ |
| MSD 9 M MSD 9 LM | 12 | 30 | 38.7 50.7 | 6 | 3.7 | 21 23 | 12 24 | M3×3 | 27.1 39.1 | 5 | $\varnothing 1.5$ |
| MSD 12 M MSD 12 LM | 14 | 40 | 44.5 60 | 8 | 4 | 28 | 15 28 | M3×4 | 31.0 46.5 | 6 | $\varnothing 1.5$ |
| MSD 15 M MSD 15 LM | 16 | 60 | 55.5 74.5 | 9 | 4 | 45 | 20 35 | M4×4.5 | 40.3 59.3 | 7 | $\varnothing 1.5$ |

| Model No. | Rail dimension | | | | | Basic load rating | | Static moment rating | | | | Weight | | |
|-------------------------------------|----------------------------------|--------------|---------|--------|-----------------------|-------------------|-----------------|----------------------|----------------|---------------|----------------|----------------|------------|-----------|
| | Width W_1 | Height H_1 | Pitch P | E std. | $D \times h \times d$ | Dynamic C kN | Static C_0 kN | M_P N-m | | M_Y N-m | | M_R N-m | Carriage g | Rail kg/m |
| | | | | | | | | Single* | Double* | Single* | Double* | | | |
| MSD 7 M MSD 7 LM | 14 ⁰ _{-0.05} | 5.2 | 30 | 10 | 6×3.2×3.5 | 1.51 2.04 | 2.46 3.79 | 6.6 17.5 | 39.0 84.0 | 6.6 17.5 | 39.0 84.0 | 17.7 27.3 | 23 31 | 0.55 |
| MSD 9 M MSD 9 LM | 18 ⁰ _{-0.05} | 7 | 30 | 10 | 6×4.5×3.5 | 2.79 3.64 | 4.37 6.39 | 15.6 33.8 | 90.3 175.2 | 15.6 33.8 | 90.3 175.2 | 40.7 59.5 | 41 57 | 0.96 |
| MSD 12 M MSD 12 LM | 24 ⁰ _{-0.05} | 8.5 | 40 | 15 | 8×4.5×4.5 | 4.05 5.28 | 6.20 9.06 | 26.3 57.0 | 151.5 294.4 | 26.3 57.0 | 151.5 294.4 | 76.3 116.6 | 70 101 | 1.55 |
| MSD 15 M MSD 15 LM | 42 ⁰ _{-0.05} | 9.5 | 40 | 15 | 8×4.5×4.5 | 7.08 9.40 | 10.18 15.26 | 62.5 135.2 | 301.4 616.1 | 62.5 135.2 | 301.4 616.1 | 216.9 325.3 | 150 126 | 2.99 |

* Single: Single carriage/ Double: Double carriages closely contacting with each other.